

ASSEMBLY MANUAL – ACRAEA 3.0

STEP BY STEP INSTRUCTIONS

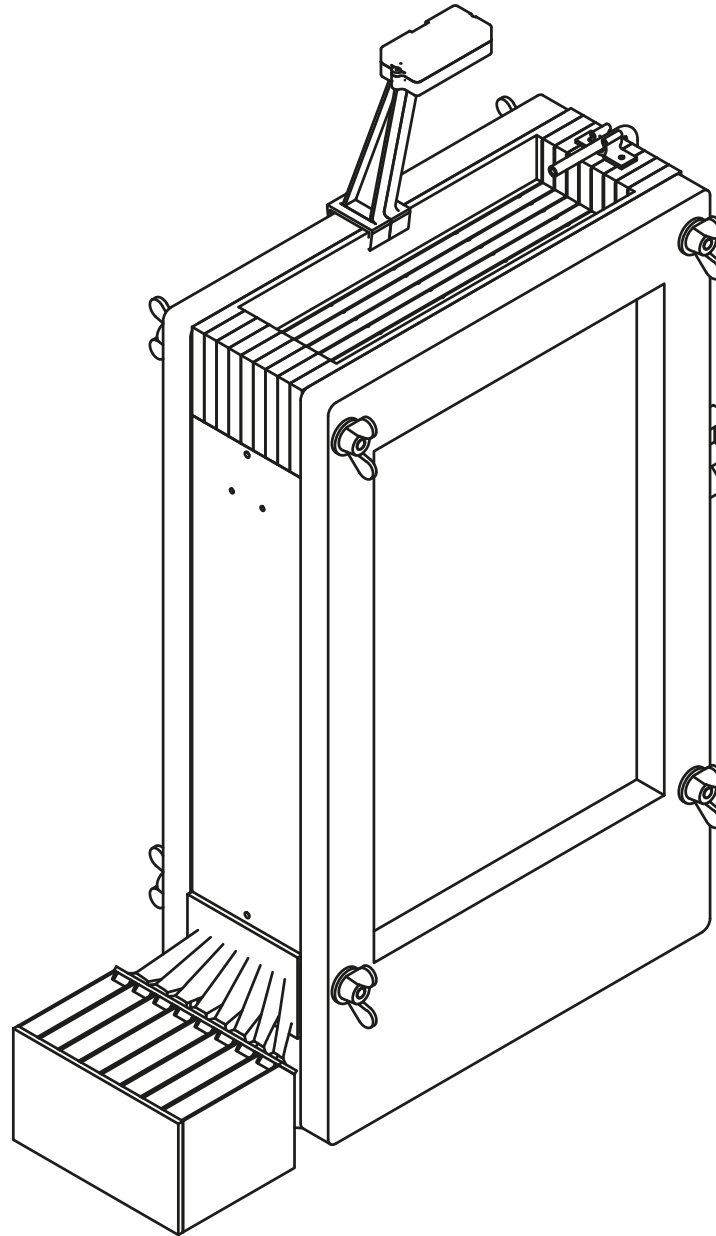
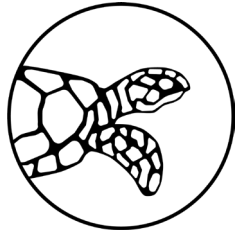

MACHINE HARDWARE &
ASSEMBLY MANUAL BY

LibreWater

<https://codeberg.org/LibreWater/Acraea-Prototype>

INDEX

Overview Modules	3
Part List	4
Step 1 Get the Backframe ready	5
Step 2 Add the first layer	6
Step 3.1 Add the Feed Sealing	7
Step 3.2 Add the Wick	8
Step 3.3 Add the Feed Spacer	9
Step 3.4 Add a Drainage and Plate	10
Step 4 Repeat step 3 six times	11
Step 5 Add the Feed Front Wall, the last Plate and Drainage	12
Step 6 Add the Casing Front Wall	13
Step 7 Align the Wicks	14
Step 8 Close the module	15
Done	16

OVERVIEW

MODULES

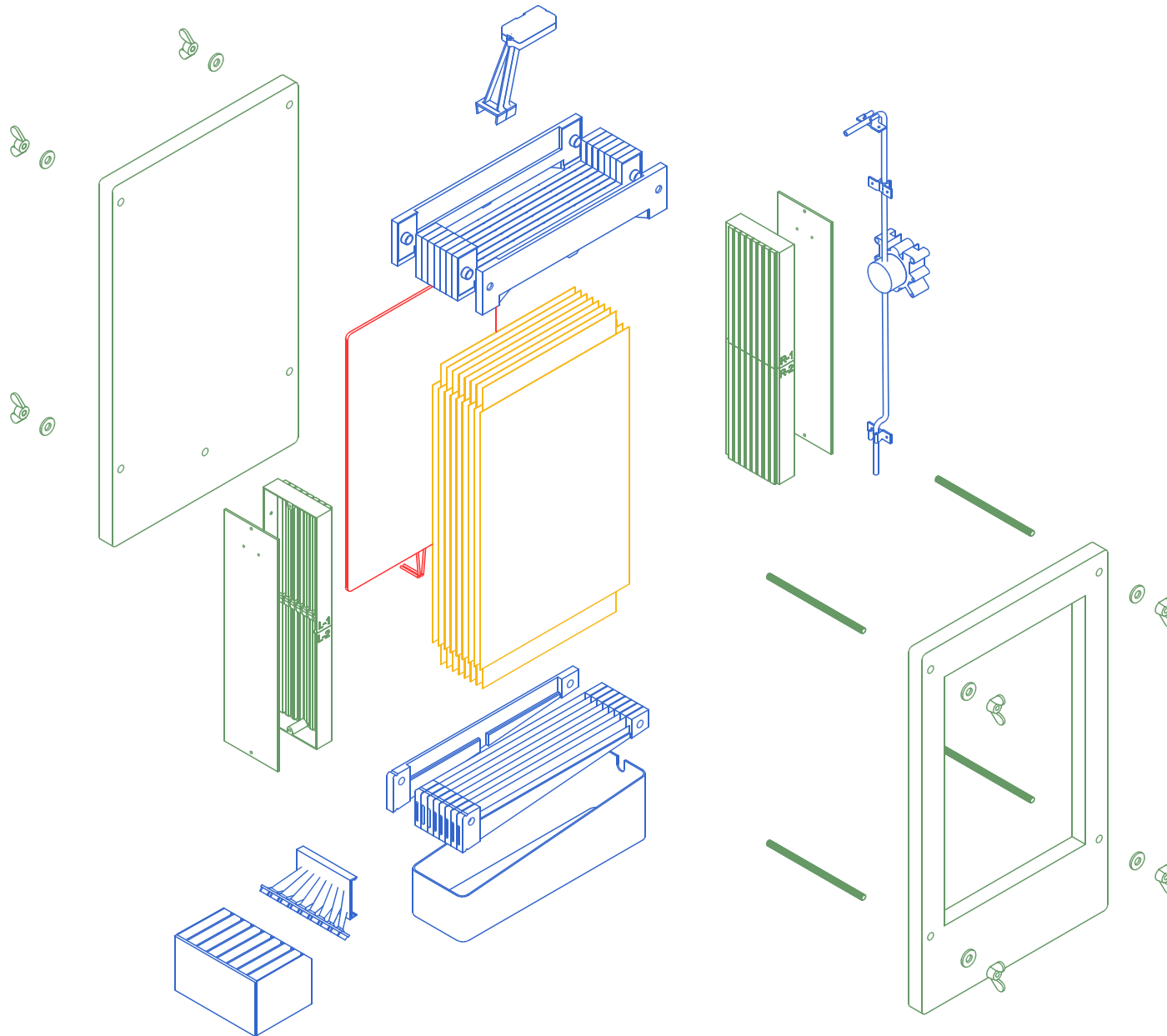

HEATING

PLATES

FLUID SYSTEM

CASING

PART LIST

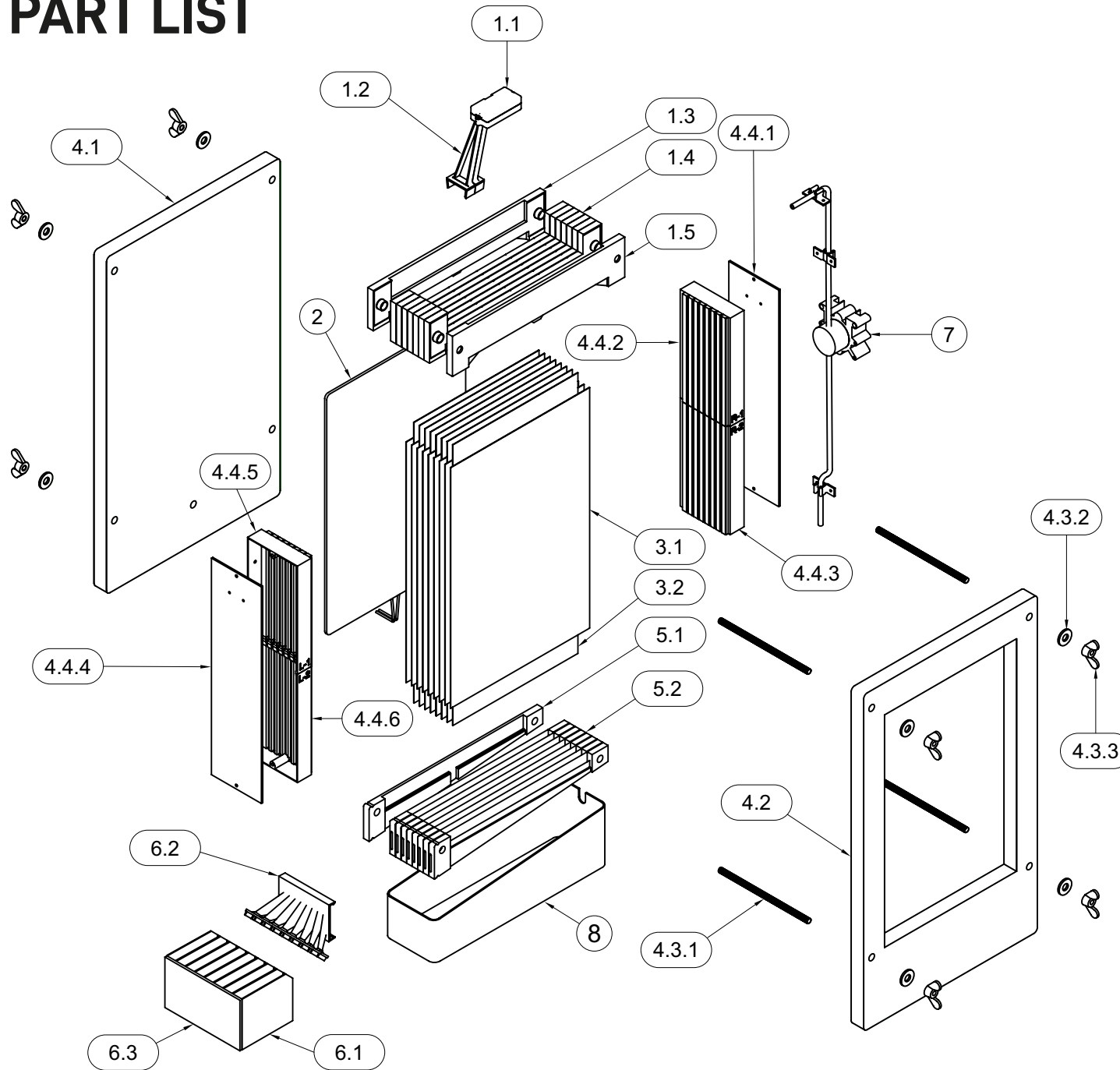

Item	Part Name	Quantity	Material
1	Feed		
1.1	Ultrasonic Sensor	1	PETG (clear)
1.2	Holder	1	PETG (clear)
1.3	Feed Back Wall	1	PETG (clear)
1.4	Feed Spacer	7	PETG (clear)
1.5	Feed Front Wall	1	PETG (clear)
2	Heating Pad	1	Prebuild
3	Plates		
3.1	Plates	9	Aluminium
3.2	Wicks	8	Cotton Textile
4	Casing		
4.1	Casing Back	1	Wood
4.2	Casing Front	1	Wood
4.3	Mounting		
4.3.1	Threaded Rod M6	4	Steel
4.3.2	Washer M6	8	Steel
4.3.3	Wing nut M6	8	Steel
4.4	Side Wall		
4.4.1	Cover-R	1	Acrylic Glass
4.4.2	Side Wall R-1	1	PETG (clear)
4.4.3	Side Wall R-2	1	PETG (clear)
4.4.4	Cover-L	1	Acrylic Glass
4.4.5	Side Wall L-1	1	PETG (clear)
4.4.6	Side Wall L-2	1	PETG (clear)
5	Drainage		
5.1	Drainage Spacer	1	PETG (clear)
5.2	Drainage	8	PETG (clear)
6	Water Measuring		
6.1	Fresh Water Tank	1	PETG (clear)
6.2	Adpater	1	PETG (clear)
6.3	Cover	1	Acrylic Glass
7	Tube Pump	1	
8	Tank Brine	1	PETG (clear)

STEP 1

GET THE BACKFRAME READY

1/8



Parts needed for this step

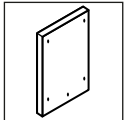

Casing Backwall

1x



Threaded Rod M6

4x



Wingnut M6

4x



Washer M6

8x

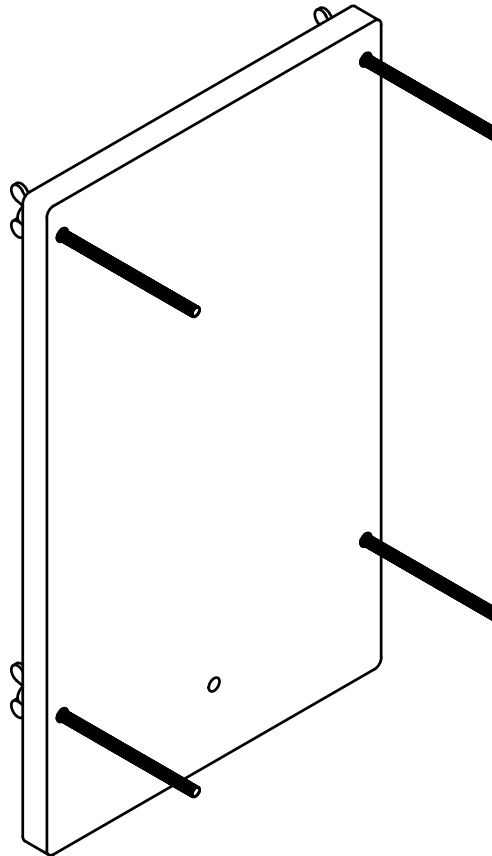

Insert the 4 threaded rods with the washers and wing nuts in to the Casing Back Wall.

Lay it flat down on a table with the wing nuts pointing down.

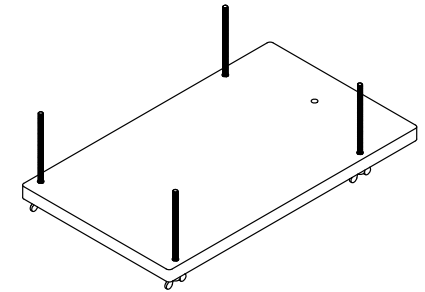

Be mindful about the threaded rods and avoid eye contact.

STEP 2

ADD THE FIRST LAYER

2/8



Parts needed for this step

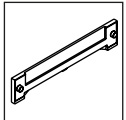

Feed Back Wall

1x

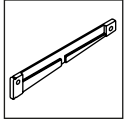

Drainage Spacer

1x

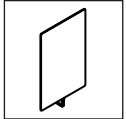

Heating Pad with Plate

1x

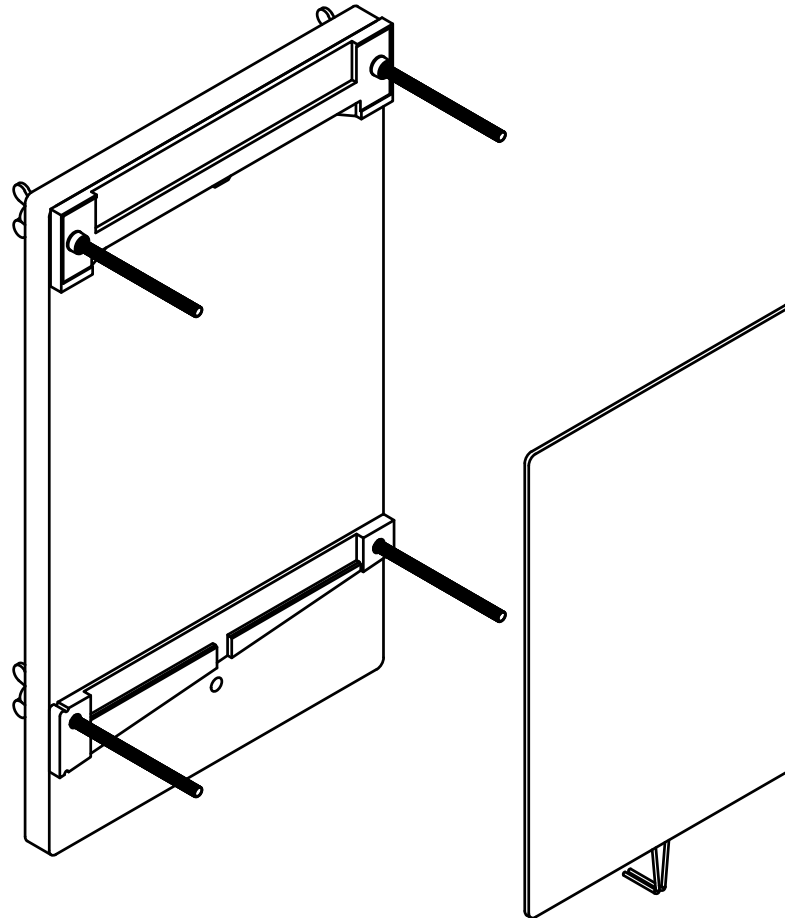

Slide the Feed Back Wall onto the top rods.

Slide the Drainage Spacer onto the bottom rods.

Align the top corners of the Heating Pad (adhered to the Plate) with the Feed Back Wall.

Guide the Heating Pad cables out.

STEP 3.1

ADD THE FEED SEALING

3/8



Parts needed for this step

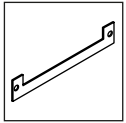

Feed Sealing

1x

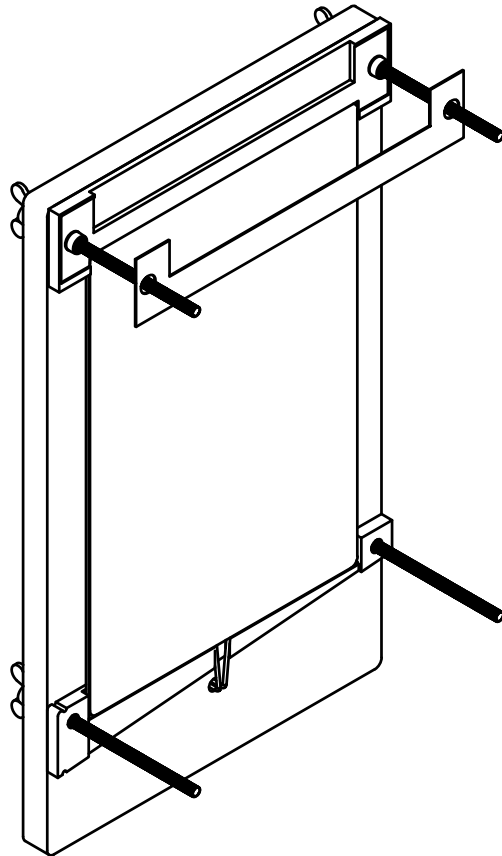

Slide the Feed Sealing onto the rods.

Make sure the material is pushed fully down on the guide pins and it sits freely.

STEP 3.2

ADD THE WICK

3/8



Parts needed for this step

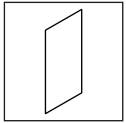

Wick
1x

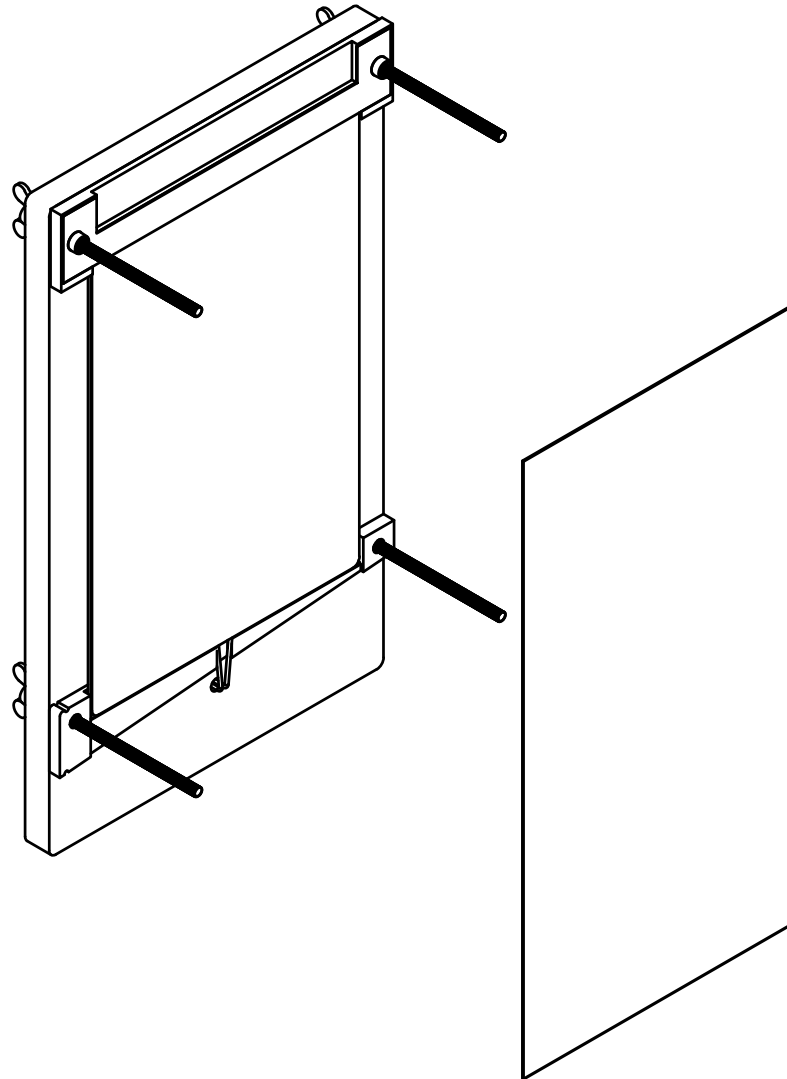

Add the Wick.

Ensure it is pointing about 0,5 cm above the bottom corner of the Feed Backwall

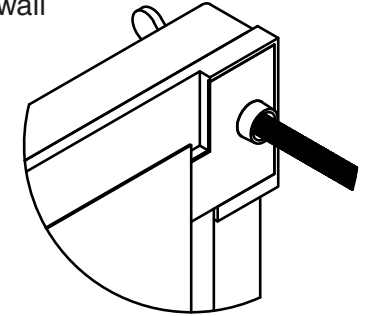

Ensure equal spacing of about 1 cm to both side corners of the Plate.

STEP 3.3

ADD THE FEED SPACER

3/8



Parts needed for this step

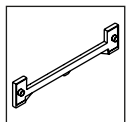

Feed Spacer

1x

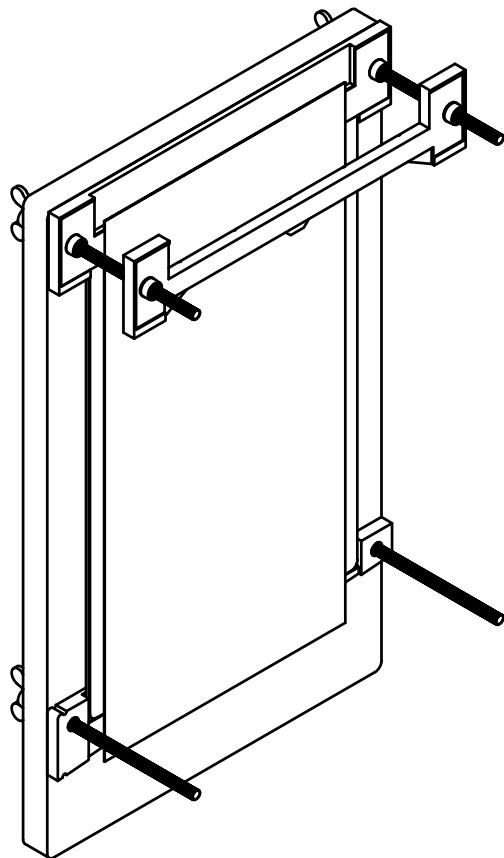

Slide the Feed Spacer onto the top rods.

STEP 3.4

ADD A DRAINAGE AND PLATE

3/8



Parts needed for this step

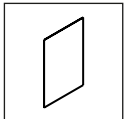

Plate

1x

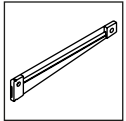

Drainage

1x

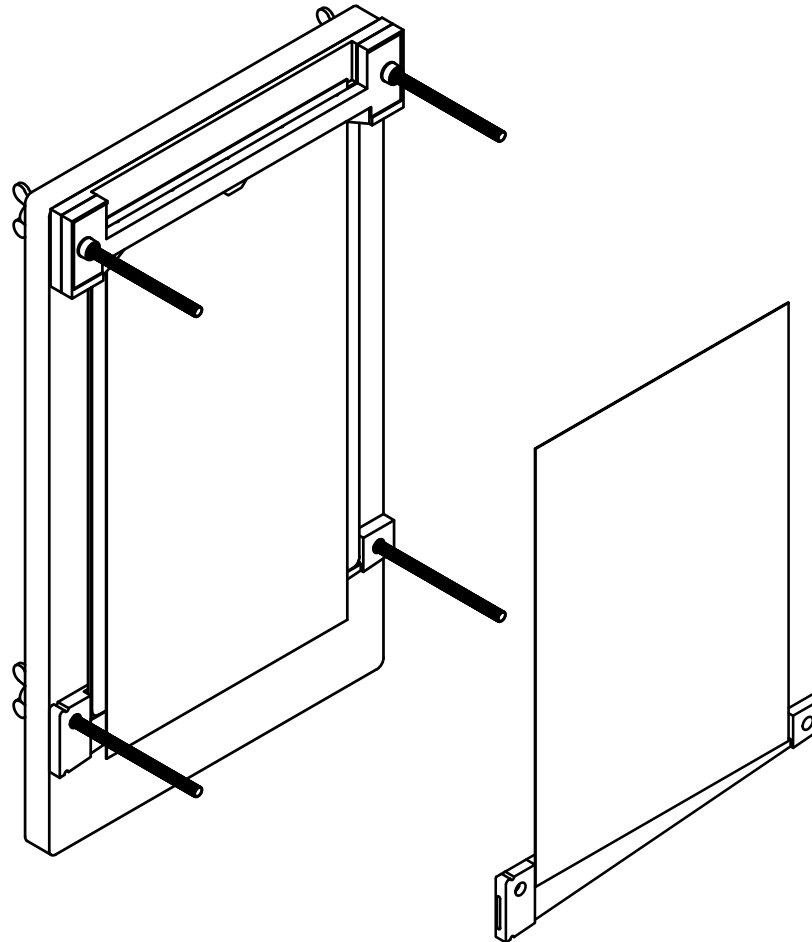

Add the Plate-and-Drainage part.
Align the Plate in the corners of the
Feed Spacer.

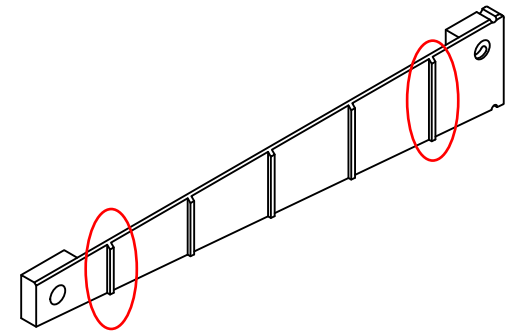

Make sure that the outermost bar on
the back of the Drainage serves to
press the Wick onto the plate.

STEP 4

REPEAT STEP 3 SIX TIMES

4/8



Parts needed for this step

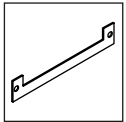

Feed Sealing

6x

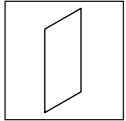

Wick

6x

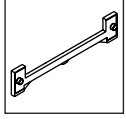

Feed Spacer

6x

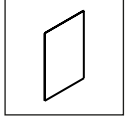

Plate

6x

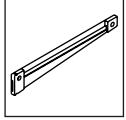

Drainage

6x

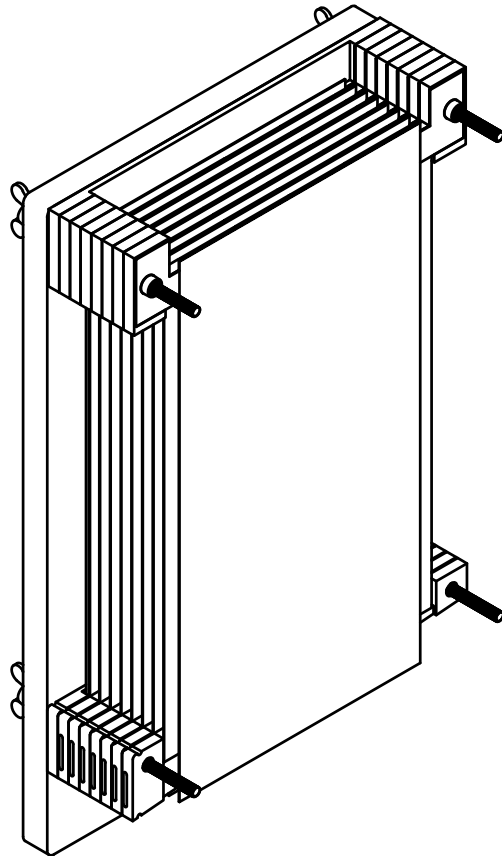

Repeat step 3 six times until it looks like that.

End with attaching the last Feed Sealing and Wick.

You should have left these parts:

Feed Front Wall, one Plate and one Drainage.

STEP 5

ADD THE FEED FRONT WALL, THE LAST PLATE AND DRAINAGE

5/8



Parts needed for this step

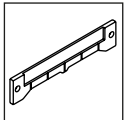

Feed Front Wall

1x

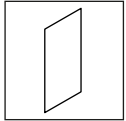

Plate

1x

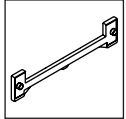

Drainage

1x

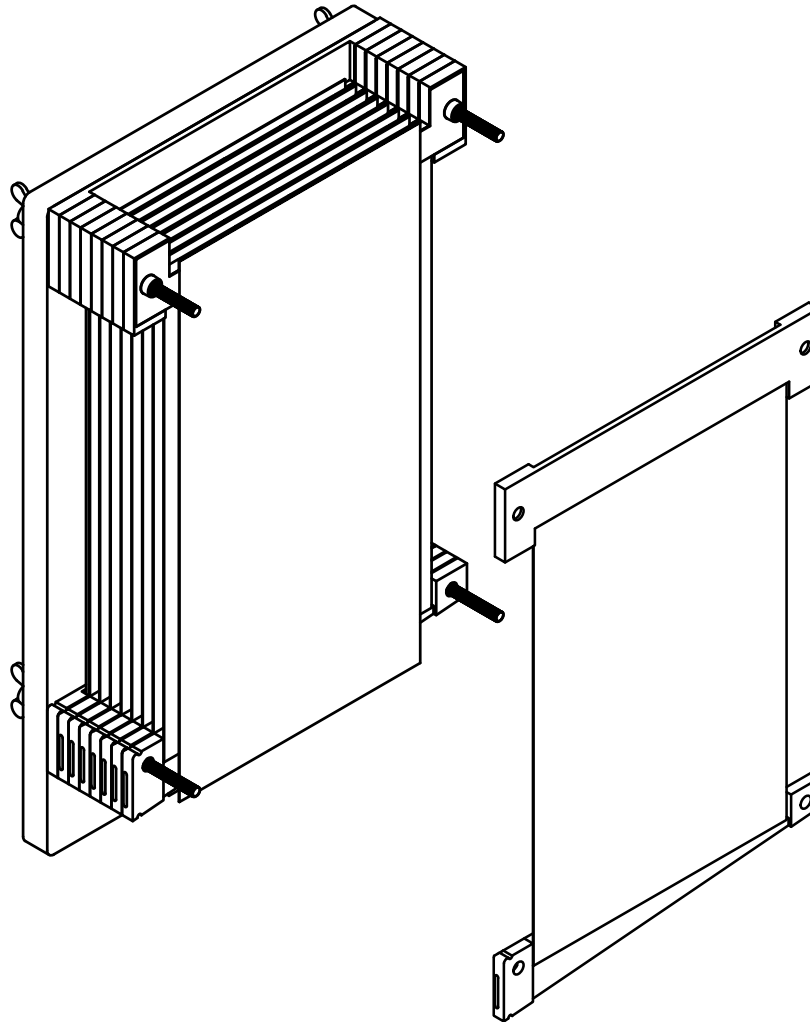

Add the Feed Front Wall with the flat side up.

Then add the last Drainage and Plate.

STEP 6

ADD THE CASING FRONT WALL

6/8

Parts needed for this step

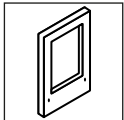

Casing Front Wall

1x

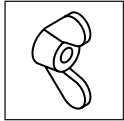

Wing Nut M6

4x

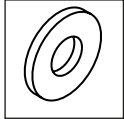

Washer M6

4x

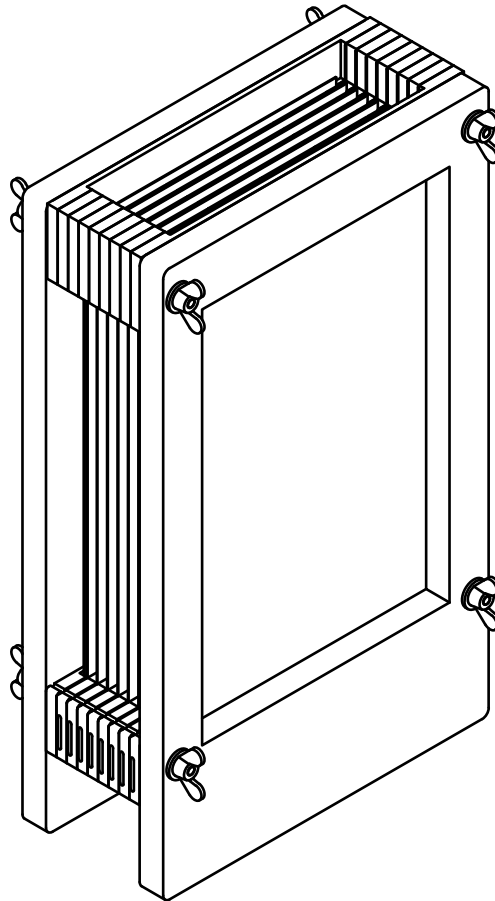

Add the Casing Front Wall.

Close the module by tightening all 4 bolts from both sides equally to a medium strength (like closing a plastic bottle).

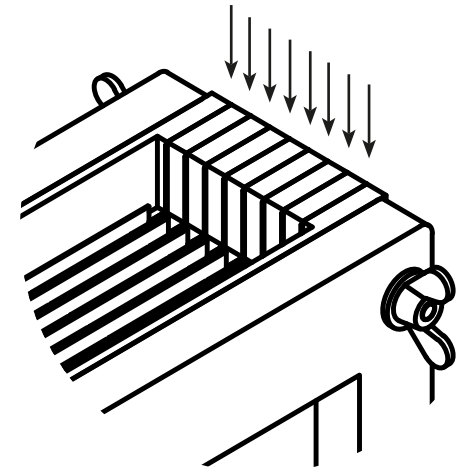

Tighten the top bolts strongly, until the limit of compression is reached and there is no gap between the parts visible on the corners.

STEP 7

ALIGN THE WICKS

7/8

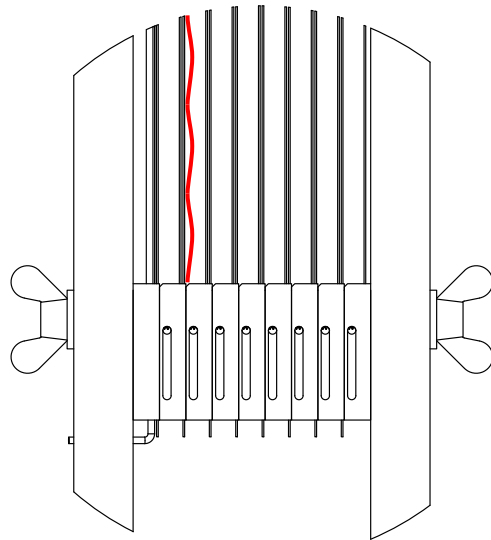
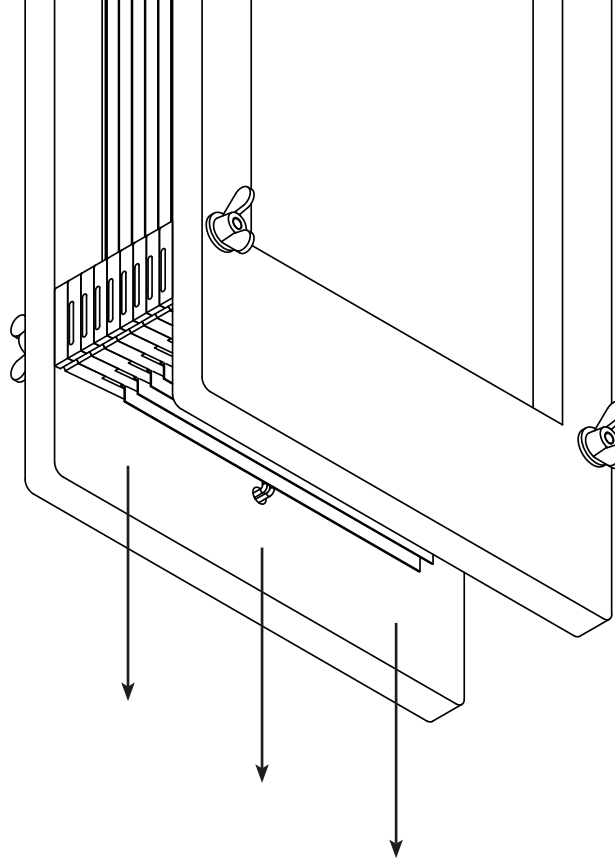

Avoid warping of the wicks!

Inspect the stages thoroughly using a torch. The Wicks have to be all be flat down on the Plates. At no point, not even with a lint, touch the other side. This will contaminate your pure water side.

Pull down the Wicks (textile cloths) to stretch them nicely.

a) If it is to hard to pull, loosen the bolts slightly

b) If the cloth is not grabbed well, tighten the bolts slightly

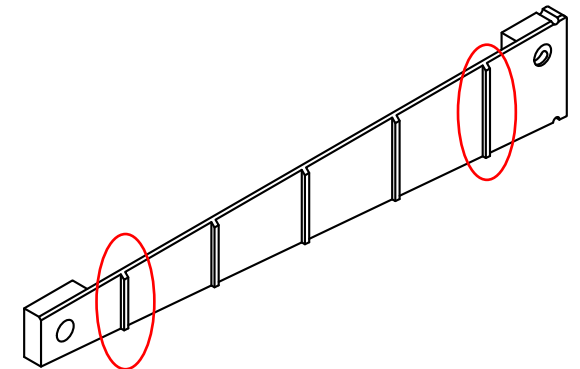

Make sure that the outermost bar on the back of the drainage serves to press the wick onto the plate.

STEP 8

CLOSE THE MODULE

8/8

Parts needed for this step

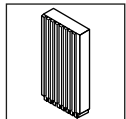

Casing Side Wall L-1

1x

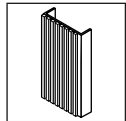

Casing Side Wall L-2

1x

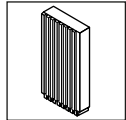

Casing Side Wall R-1

1x

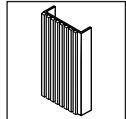

Casing Side Wall R-2

1x

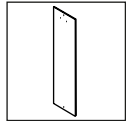

Cover

2x

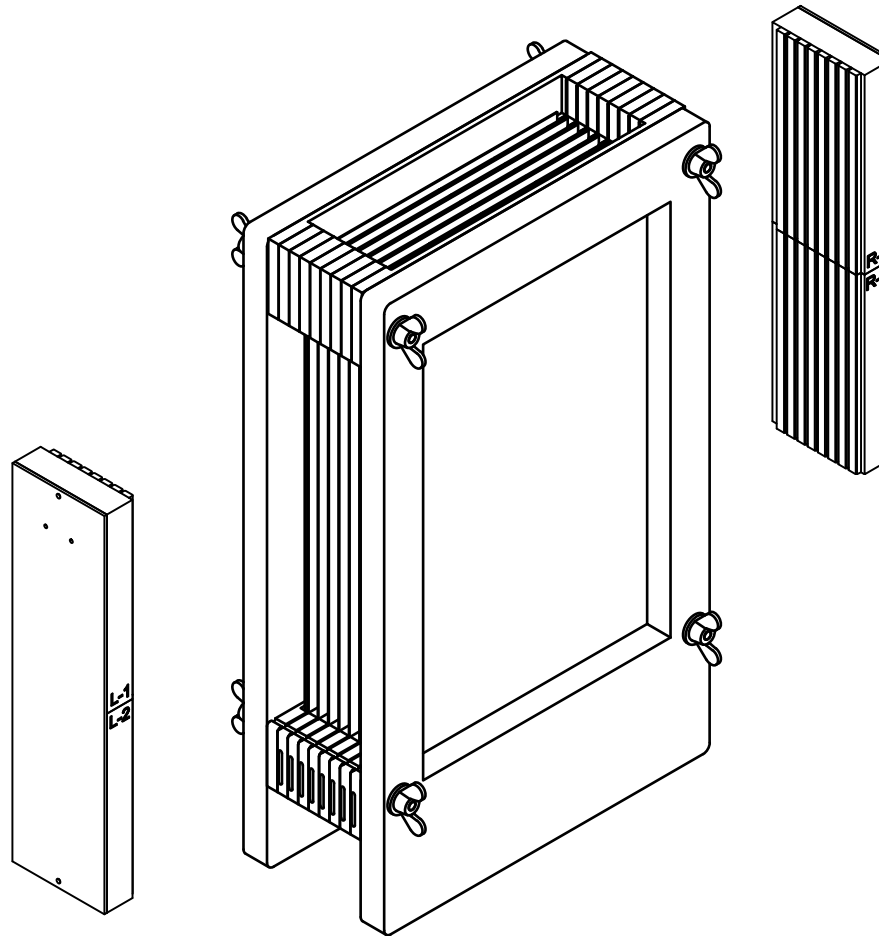

Add the casing Sidewall, starting with the bottom half. The side facing the heating system has a broader flat side.

Slide the top half onto the plates, starting again from the middle up.

Attach the cover.

Repeat for the other side.

Finally: Tighten all the Wing Nuts on both sides well.

CONGRATULATIONS

YOU ASSEMBLED THE MOST CRITICAL
PARTS OF ACRAEA 3.0

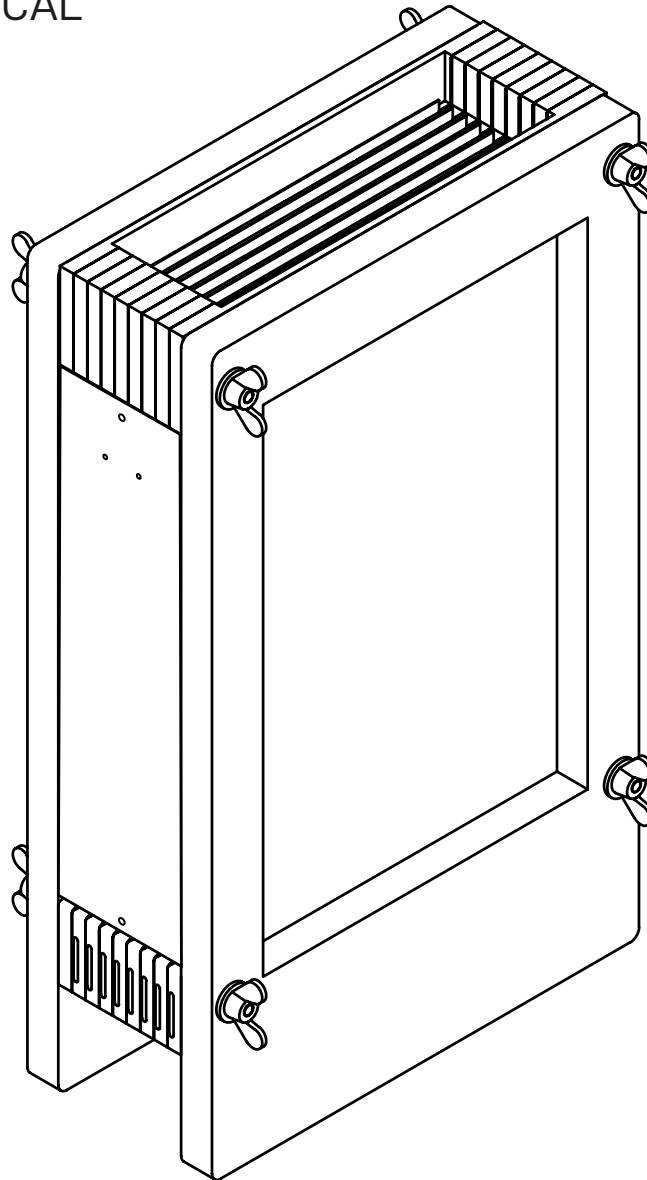

You can now add accessories like

Tank

To collect overflowing water called „Brine“

Tube Pump

To automate refill of the Feed Tank.

Sensor

To measure the water level in the Feed Tank and activating the Tube Pump.

Documentation and installation instructions are forthcoming.

